

DIM	80	100
A (COB)	1671 [65.8]	1661 [65.4]
B	692 [27.2]	992 [39.0]

MODEL	ALTERNATOR	GENSET WGT (WET) W/ ENCL		ENCLOSURE ONLY		
		KG	LBS	KG	LBS	
80	4S7	STEEL WEATHER	1470	3241	154	340
		STEEL SOUND	1481	3264	163	363
		ALUM SOUND	1419	3128	103	227
	4S9/4V9	STEEL WEATHER	1522	3357	154	340
		STEEL SOUND	1533	3380	163	363
		ALUM SOUND	1471	3244	103	227
4P10X	STEEL WEATHER	1230	2704	154	340	
	STEEL SOUND	1241	2727	163	363	
	ALUM SOUND	1179	2591	103	227	
4R9X/4T9X	STEEL WEATHER	1454	3205	154	340	
	STEEL SOUND	1465	3228	163	363	
	ALUM SOUND	1403	3092	103	227	

MODEL	ALTERNATOR	GENSET WGT (WET) W/ ENCL		ENCLOSURE ONLY		
		KG	LBS	KG	LBS	
100	4S9	STEEL WEATHER	1522	3357	154	340
		STEEL SOUND	1533	3380	163	363
		ALUM SOUND	1471	3244	103	227
4V11	STEEL WEATHER	1644	3625	154	340	
	STEEL SOUND	1655	3648	163	363	
	ALUM SOUND	1593	3512	103	227	
4S13	STEEL WEATHER	1657	3653	154	340	
	STEEL SOUND	1668	3676	163	363	
	ALUM SOUND	1606	3540	103	227	
4R9X	STEEL WEATHER	1454	3205	154	340	
	STEEL SOUND	1465	3228	103	363	
	ALUM SOUND	1403	3092	154	227	
4R12X	STEEL WEATHER	1540	3395	163	340	
	STEEL SOUND	1551	3418	154	363	
	ALUM SOUND	1489	3282	103	227	
4T13X	STEEL WEATHER	1557	3434	154	340	
	STEEL SOUND	1568	3457	163	363	
	ALUM SOUND	1506	3321	103	227	

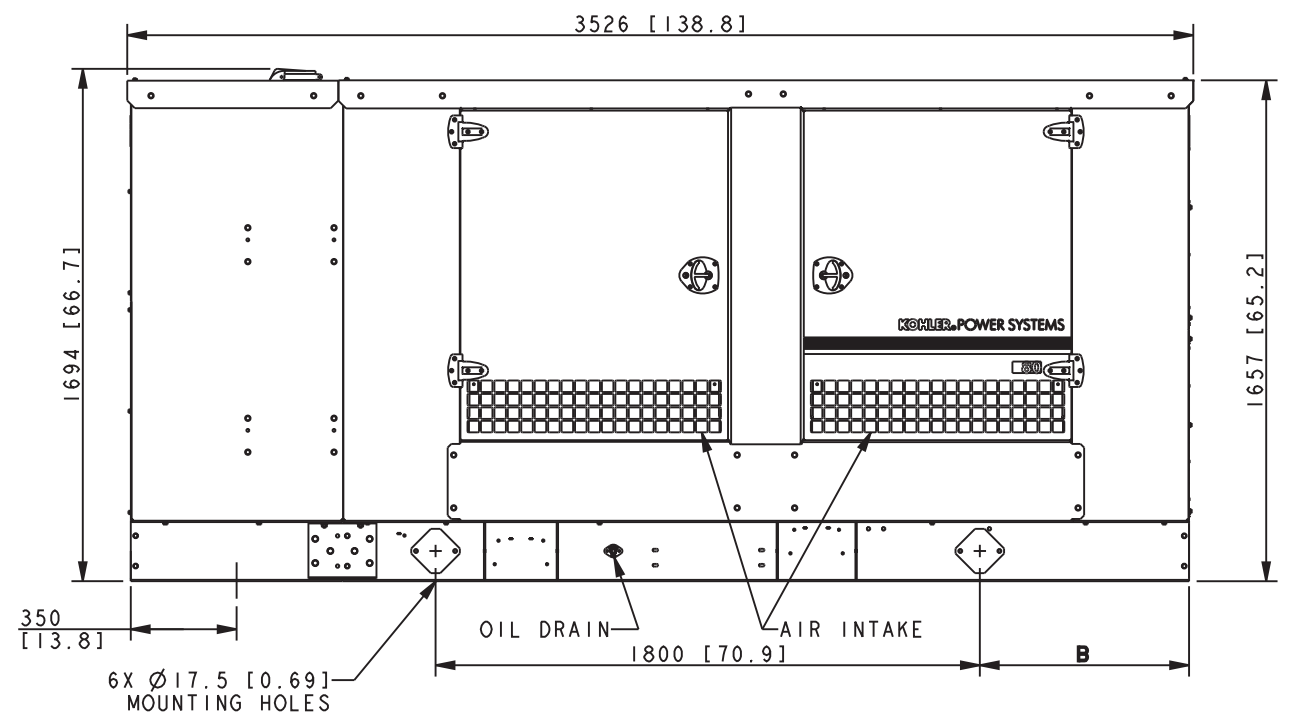
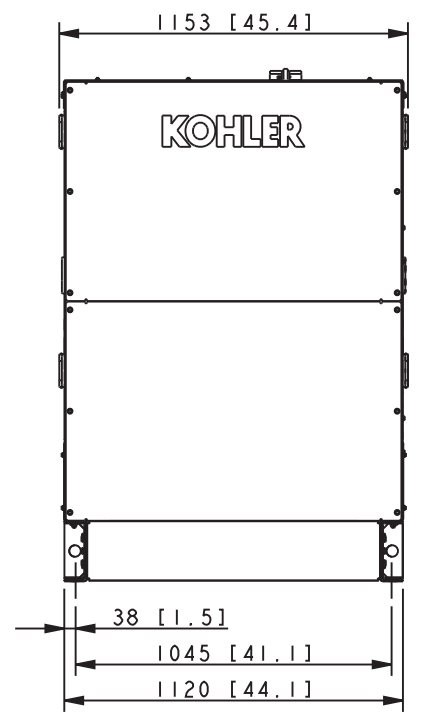
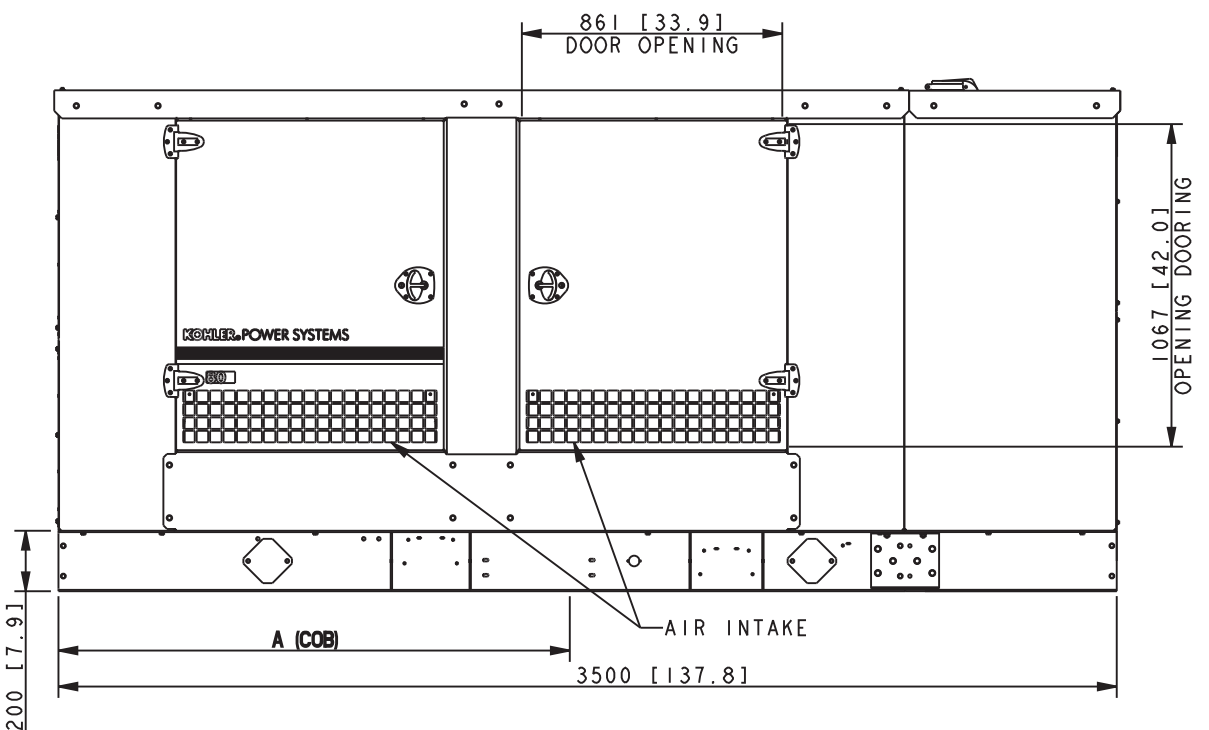
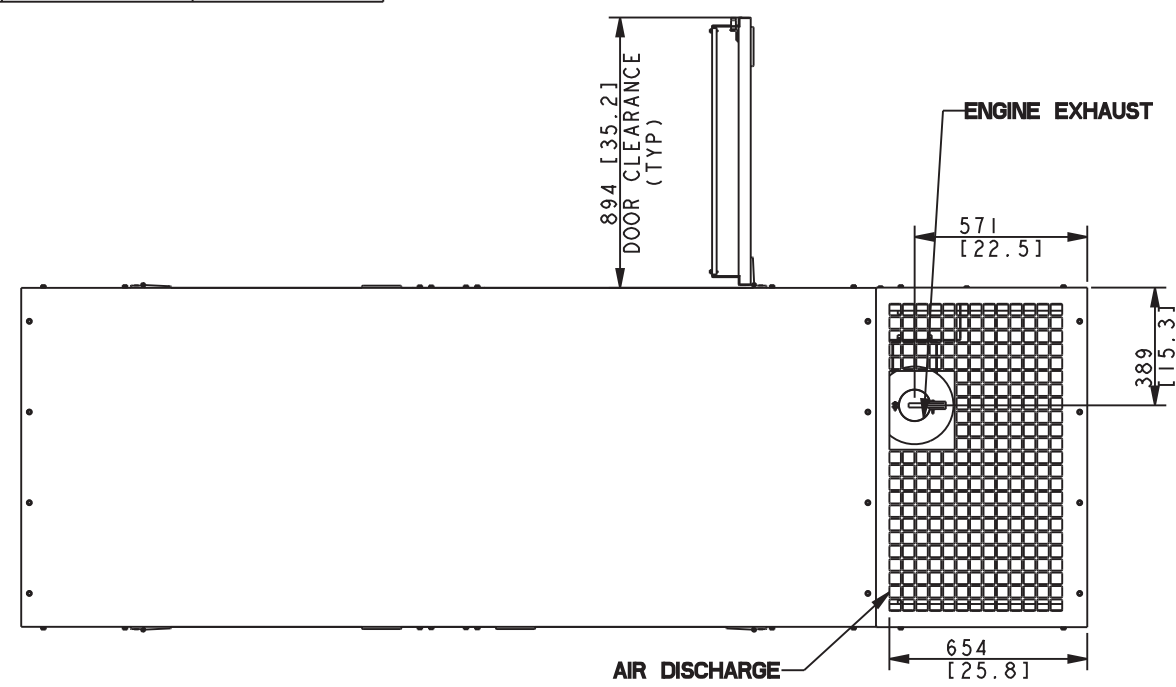

80 MODEL 4S7/4V9
 100 MODEL 4S9/4S13/4V11
 RECONNECTABLE
 IMPROVED MOTOR STARTING (IMS) RECONNECTABLE
 & 600V ALTERNATORS
 5.7L GM TURBO & TURBO/CAC

REV	DATE	ON COMPOSITE DWGS. SEE PART NO. FOR REVISION LEVEL	BY
-	5-3-10	NEW DRAWING [89178-3]	KRH
A	6-8-10	(C/D-2) 80 MODEL 4V9 WAS 4S9, 100 MODEL 4V11/4S13 GENSET W/ENCL WEIGHTS UPDATED [89934]	CWF
B	7-22-11	(D-5,3) 4V9, 4P10X, 4R9X, 4T9X, 4R12X AND 4T13X WEIGHTS ADDED [91796]	SAM

KOHLER CO. METRIC PRO-E

POWER SYSTEMS, KOHLER, WI 53044 U.S.A.

THIS DRAWING IN DESIGN AND DETAIL IS KOHLER CO. PROPERTY AND MUST NOT BE USED EXCEPT IN CONNECTION WITH KOHLER CO. WORK. ALL RIGHTS OF DESIGN OR INVENTION ARE RESERVED.

TITLE: **DIMENSION PRINT, 80/100KW GM ENCLOSURE**

SCALE 0.08 CAD NO. SHEET 1 of 1

ADV-7892 D

DIMENSIONS IN [] ARE IN ENGLISH EQUIVALENTS.